

HAULOTTE STAR10 - ELECTRIC VERTICAL MAST BOOM LIFT



Working Height: 10m



Maximum Outreach: 3m



Cage Capacity: 2 or SWL



Safe Working Load: 200kgs



GVW: 2,677kgs



IPAF Category 3B

The Star10 is the perfect tool for working in narrow aisles in factories, warehouses and supermarkets. They are also very popular for heating, ventilation & air-conditioning work (HVAC) and at sporting and other events, due to their light weight. The versatile jib gives 3m horizontal reach and the telescopic vertical mast ensures there is zero tail-swing.

HAULOTTE STAR10 - ELECTRIC VERTICAL MAST BOOM LIFT



Our Star10 Vertical Mast Boom Lifts are designed to be used on even ground and can be used indoors and outdoors (1-person maximum outdoors). Because these machines are so versatile, they are a smart choice for the logistic, retail industry, maintenance & restoration sectors.

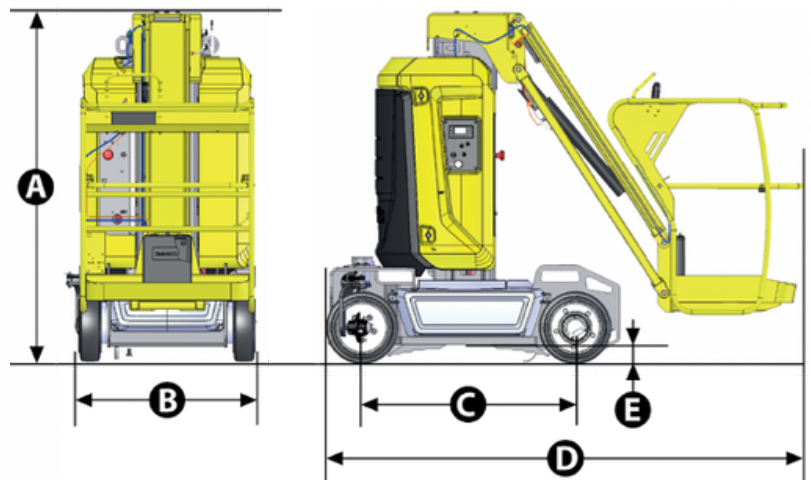
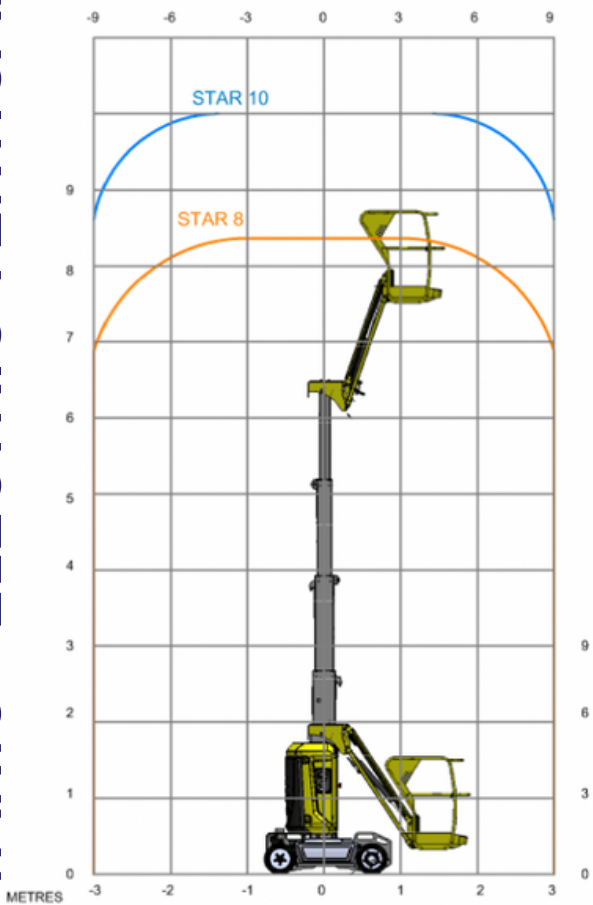

D Length	2.7 m
B Width	1 m
Tailswing	0 cm
C Wheelbase	1.2 m
A Height - stowed	1.99 m
E Ground clearance	10 cm

Max Working Height: 10m
 Max Horizontal Outreach: 3m
 Max Cage Floor Height: 8m
 Max SWL indoors (2 persons): 200kgs
 Max SWL outdoors (1 person): 200kgs

Max Persons in Cage: 2 or SWL
 Non-marking tyres: Yes
 Power: Battery
 Terrain: Solid/flat
 IPAF Category: 3B



www.warrenaccess.co.uk

NEWCASTLE: 0191 236 7120
 Baker Road, Nelson Park West, Cramlington, NE23 1WL

HUNTINGDON: 01480 891 581
 Unit 4D & 4E, Grange Farm, Abbots Ripton, Huntingdon, PE28 2PH